

# > URBAN DECO TNA / MDA / ADA

DESIGNED FOR STREET AND AMENITY LIGHTING



# > URBAN DECO TNA / MDA / ADA

## ATENEA [ TNA ]



TNA-15. /CLPB.AF\*

Clear Polycarbonate Bowl



TNA-15. /CLCG.AF\*

Clear Curved Toughened Glass



TNA-15. /CLFG.AF\*

Clear Flat Toughened Glass

## MEDEA [ MDA ]



MDA-15. /CLPB.AF\*

Clear Polycarbonate Bowl



MDA-15. /CLCG.AF\*

Clear Curved Toughened Glass



MDA-15. /CLFG.AF\*

Clear Flat Toughened Glass

## AIDA [ ADA ]



ADA-15. /CLPB.AF\*

Clear Polycarbonate Bowl



ADA-15. /CLCG.AF\*

Clear Curved Toughened Glass



ADA-15. /CLFG.AF\*

Clear Flat Toughened Glass

## TECHNICAL DESCRIPTION

<b>Body</b>	Cast aluminium. Gear access from bottom
<b>Canopy</b>	Notched sheet aluminium
<b>Reflector*</b>	Anodized and sealed single piece aluminium. (AF) Asymmetric frontal or (SR) Asymmetric longitudinal
<b>Enclosure</b>	Flat glass, curved glass or a polycarbonate bowl. Lamp access from bottom
<b>Mounting</b>	Vertical, side, wall and catenary mountings available
<b>Finishes</b>	Polyester powder coat to colour of choice. (Wet paint option available on request)
<b>Optic Water Tight</b>	IP-66

**VERTICAL MOUNTING**

**V2** 2 Vertical Brackets

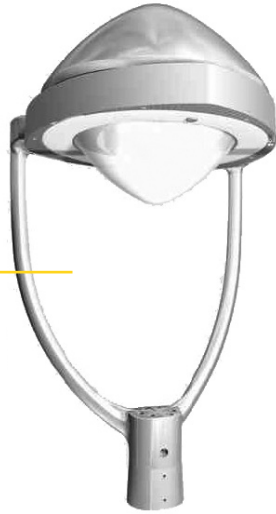

**V3** 3 Vertical Brackets

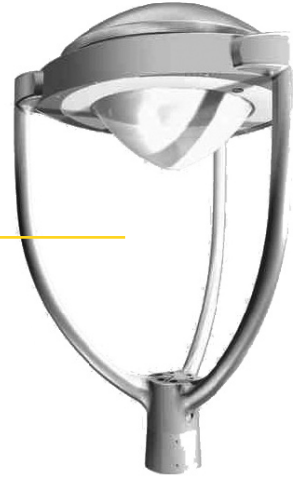

**WALL MOUNTING**



**SIDE MOUNTING**



**CATENARY MOUNTING**

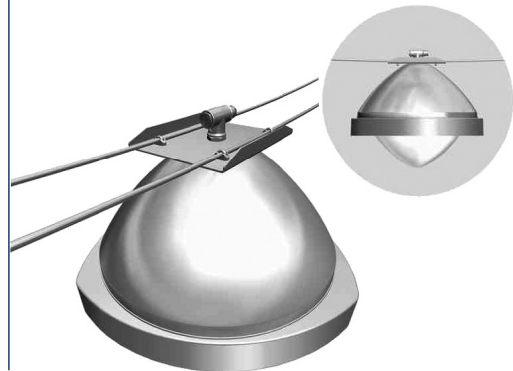

**COLUMN ACCESSORIES**

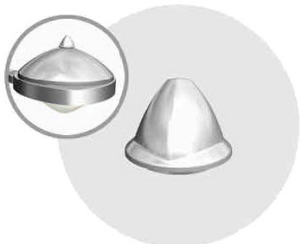

**VRS** Luminaire Crown



**RSC** Column Crown



**BP1** Single Banner Arm



**BP2** Double Banner Arm

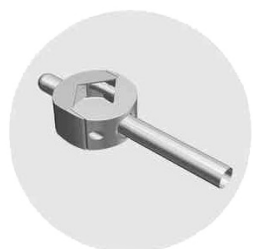

**VBC** Column Clamp



**VBVS 60/76mm**  
Single Vertical Coupling  
ø60 or 76mm



**VBVD 60/76mm**  
Double Vertical Coupling  
ø60 or 76mm

## DIMENSIONS AND WEIGHTS

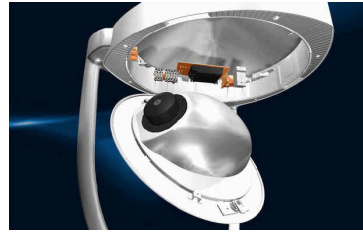

TNA / MDA / ADA Gear Access

Type	A	B	C	D	E	F
MDA-15.V2/CLCG.	1052	815	∅76x100	∅60x100	644	603
TNA-15.V2/CLCG.	1132	815	∅76x100	∅60x100	644	603
ADA-15.V2/CLCG.	1002	815	∅76x100	∅60x100	644	603

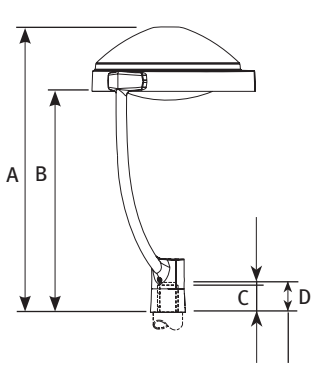

MDA-15.V2/CLCG.

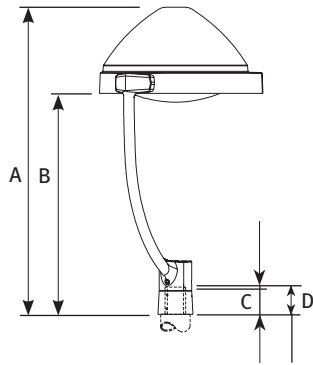

TNA-15.V2/CLCG.

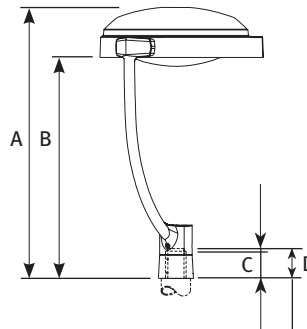

ADA-15.V2/CLCG.

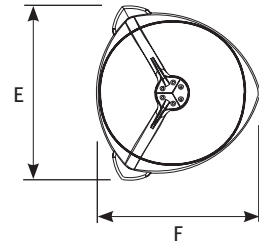

MDA / TNA / ADA

## LAMPS

TNA-15 / MDA-15 / ADA-15



**GX24q-5**  
FL 57W



**GES (E-40)**  
HPS 100W  
HPS 150W  
HPS 250W



**ES (E-27)**  
HPS 70W



MH 150W  
MH 250W

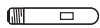

MH 100W

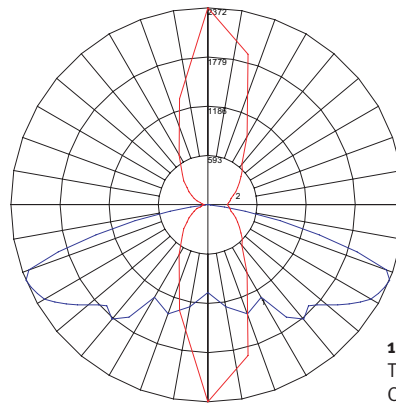

150W HPS  
Typical Polar  
Curve



KENDELIER LIGHTING LIMITED  
25 AINTREE AVE  
AIRPORT OAKS  
AUCKLAND  
NEW ZEALAND

TEL +64 9 915 1083  
FAX +64 9 915 1087

[SALES@KENDELIER.CO.NZ](mailto:SALES@KENDELIER.CO.NZ)  
[WWW.KENDELIER.CO.NZ](http://WWW.KENDELIER.CO.NZ)

NZ FREE 0800 536 335  
AUSTRALIA FREE 1800 553 817